

CV#	Function/Default Value	CV#	Function/Default Value	CV#	Function/Default Value
81	Route 1 Selection	255	97	Route 9 Selection	0
82	Route 1 Switch State	255	98	Route 9 Switch State	0
83	Route 2 Selection	255	99	Route 10 Selection	0
84	Route 2 Switch State	0	100	Route 10 Switch State	0
85	Route 3 Selection	0	101	Route 11 Selection	0
86	Route 3 Switch State	0	102	Route 11 Switch State	0
87	Route 4 Selection	0	103	Route 12 Selection	0
88	Route 4 Switch State	0	104	Route 12 Switch State	0
89	Route 5 Selection	0	105	Route 13 Selection	0
90	Route 5 Switch State	0	106	Route 13 Switch State	0
91	Route 6 Selection	0	107	Route 14 Selection	0
92	Route 6 Switch State	0	108	Route 14 Switch State	0
93	Route 7 Selection	0	109	Route 15 Selection	0
94	Route 7 Switch State	0	110	Route 15 Switch State	0
95	Route 8 Selection	0	111	Route 16 Selection	0
96	Route 8 Switch State	0	112	Route 16 Switch State	0



TEAM DIGITAL

Improving the world of DCC

SMD82 Switch Machine Driver

- > DCC compatible accessory decoder
- > Drives eight solenoid and/or stall type machines
- > 16 programmable remote controlled routes
- > 13 inputs for programmable local routes
- > Five conditional routes
- > “Smart” Programming

8 Output Specifications

Each output - 3 amps max for 30 seconds max
Auxiliary power as shown in section 6.3 - 20 volts max

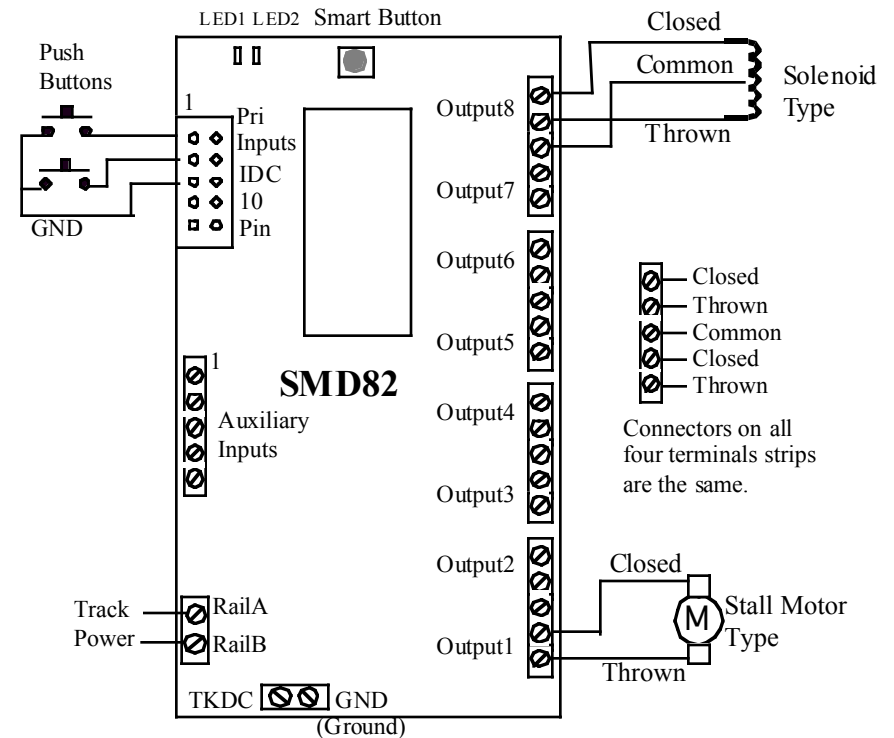

WARNING: This product contains a chemical known to the state of California to cause cancer, birth defects or other reproductive harm.

TEAM DIGITAL, LLC
3111 Timber Valley Dr
Kokomo IN 46902
www.teamdigital1.com

1 Introduction

The SMD82 is capable of driving eight solenoid and/or stall motor type switch machines. It contains a Capacitor Discharge Unit to store energy. A discharge of this energy is used to energize the solenoid to change the switch state. Using a CDU reduces the current drawn from the track to a small level sufficient to recharge the CDU. However, once the CDU has been discharged (a switch state changed) a time period is required for the CDU to recharge. This is typically about three seconds. Since more than one switch may be requested to change state at the same time, as in a local route, the requests are held so that each switch may change state in turn. A stall motor type does not use the CDU and therefore, no re-charge time is required when activated.

Caution: The CDU retains a voltage charge several minutes after power is removed.

The eight outputs of the SMD82 can individually be assigned any address from 1 to 2040. There are 13 inputs available for local control. An addition eight inputs are available with the use of some resistors.

Two types of route control are supported. The remote controlled routes are controlled from the throttle just like a single switch is, except that multiple switches may be activated. The local routes are activated by using the inputs. Routes are configured by programming the respective CVs as to which outputs are selected in the route and the output state. Remote controlled routes are in two groups of eight. Each group has a group address to allow the throttle to access it.

2 Getting Started

The SMD82 comes from the factory ready to use. It is programmed to drive solenoid switch machines (three wire). An example of a three wire (twin coil) type switch machine is an Atlas Snap Switch TM or a Peco. The eight outputs are programmed with addresses one to eight respectively. Connect the outputs of the SMD82 to the solenoid switch machines and RAIL A and RAIL B terminals to the track power as shown in the diagram on the front page. You are now ready to control your switches from the throttle.

You can control the outputs from fascia buttons by connecting them to the primary or the auxiliary inputs. The eight primary inputs, when grounded, will toggle the eight outputs respectively. The five auxiliary inputs, when grounded, will close the first five outputs respectively. They can also be directly connected to other devices to set a switch for correct alignment for approaching trains. See the application section.

Two routes have been programmed. By issuing switch commands from the throttle you can execute routes. Throwing switch 101 will cause all the outputs to be thrown and closing switch 101 will cause all the outputs to be closed.

If you want to change the type of switch machine an output drives or some of the output addresses go on to the “Smart” Programming section. If you want to customize the SMD82 such as implementing custom routes, go on to the Configuration Variables section.

Note: Switch or turnout position can be referred to by throw (t) or Reverse (R) and close (c) or Normal (N). Throw and close are used in this document.

7 Summary of Configuration Variables

CV#	Function/Default Value		CV#	Function/Default Value	
1	Output 1 Address	1	41	Pri Input 4 Route Number	0
2	Output On Time	31	42	Pri Input 4 Action	70
3	Output 1 Configuration	0	43	Pri Input 5 Route Number	0
4	Output 2 Configuration	0	44	Pri Input 5 Action	86
5	Output 3 Configuration	0	45	Pri Input 6 Route Number	0
6	Output 4 Configuration	0	46	Pri Input 6 Action	102
7	Manufacturer Version No.	-	47	Pri Input 7 Route Number	0
8	Manufacturer ID	25	48	Pri Input 7 Action	118
9	Output 1 Address Adder	0	49	Pri Input 8 Route Number	0
10	Output 5 Configuration	0	50	Pri Input 8 Action	134
11	Output 6 Configuration	0	51	Sec Input 1 Route Number	0
12	Output 7 Configuration	0	52	Sec Input 1 Action	0
13	Output 8 Configuration	0	53	Sec Input 2 Route Number	0
14	Output 2 Address	2	54	Sec Input 2 Action	0
15	Output 2 Address Adder	0	55	Sec Input 3 Route Number	0
16	Output 3 Address	3	56	Sec Input 3 Action	0
17	Output 3 Address Adder	0	57	Sec Input 4 Route Number	0
18	Output 4 Address	4	58	Sec Input 4 Action	0
19	Output 4 Address Adder	0	59	Sec Input 5 Route Number	0
20	Output 5 Address	5	60	Sec Input 5 Action	0
21	Output 5 Address Adder	0	61	Sec Input 6 Route Number	0
22	Output 6 Address	6	62	Sec Input 6 Action	0
23	Output 6 Address Adder	0	63	Sec Input 7 Route Number	0
24	Output 7 Address	7	64	Sec Input 7 Action	0
25	Output 7 Address Adder	0	65	Sec Input 8 Route Number	0
26	Output 8 Address	8	66	Sec Input 8 Action	0
27	Output 8 Address Adder	0	67	Aux Input 1 Route Number	0
28	reserved	0	68	Aux Input 1 Action	18
29	Decoder Configuration	0	69	Aux Input 2 Route Number	0
30	reserved	0	70	Aux Input 2 Action	34
31	Ops Mode Loco Address	0	71	Aux Input 3 Route Number	0
32	reserved	0	72	Aux Input 3 Action	50
33	Pwr On State - Outputs 1-4	0	73	Aux Input 4 Route Number	0
34	Pwr On State - Outputs 5-8	0	74	Aux Input 4 Action	66
35	Pri Input 1 Route Number	0	75	Aux Input 5 Route Number	0
36	Pri Input 1 Action	22	76	Aux Input 5 Action	82
37	Pri Input 2 Route Number	0	77	Route group 1-8 Address	101
38	Pri Input 2 Action	38	78	Route group 1-8 Address Adder	0
39	Pri Input 3 Route Number	0	79	Route group 9-16 Address	0
40	Pri Input 3 Action	54	80	Route group 9-16 Address Adder	0

CV77 & 78 should be the same for both SMD82s because when you execute the route with one switch command both SMD82s will respond.

CV81 & 82 of the first SMD82 will determine how switches 1 to 8 operate in route 1.
 CV81 & 82 of the second SMD82 will determine how switches 9 to 16 operate in route 1.

CV83 & 84 of the first SMD82 will determine how switches 1 to 8 operate in route 2.
 CV83 & 84 of the second SMD82 will determine how switches 9 to 16 operate in route 2.
etc

This applies for routes 1 to 8 because the CV77 & CV78 values are the same for both SMD82s. If you want routes 9 to 16 in both SMD82s to function together then the CV79 & CV80 values must be the same for both SMD82s.

6.2 Other Input Devices

Typically you may connect push buttons to the SMD82 inputs as shown in section 4.4. However, the primary input connector provides a 5 volt source, so DBD2s (block detectors) can be powered and when connected to an input a route or switch can be controlled. Using primary input 1 and Aux input 1 a conditional route can be set up. When a train is in a siding and another train crosses the trigger section, the two switches can be correctly aligned. If the siding is not occupied the trigger section will have no effect.

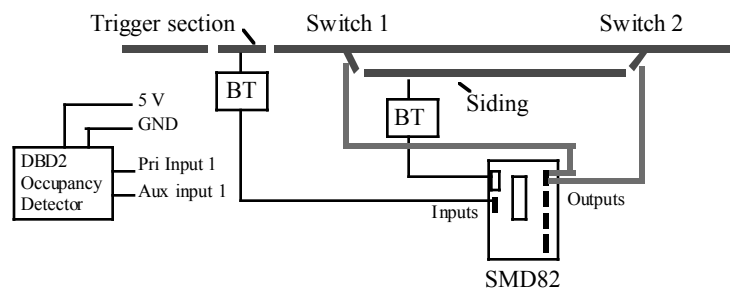

6.3 Driving Other Devices

The SMD82 can be used to turn on devices other than switch machines. In these cases auxiliary power is required. If the load is an inductance, a diode is required to suppress the positive voltage transient when the load is turned off. An example of an inductance load is the Kadee electric uncoupler #307. The diagram shows a lamp and an inductive load.

Note: The common connection is intended only to provide power to solenoid type switch machines. Other uses will result in improper operation.

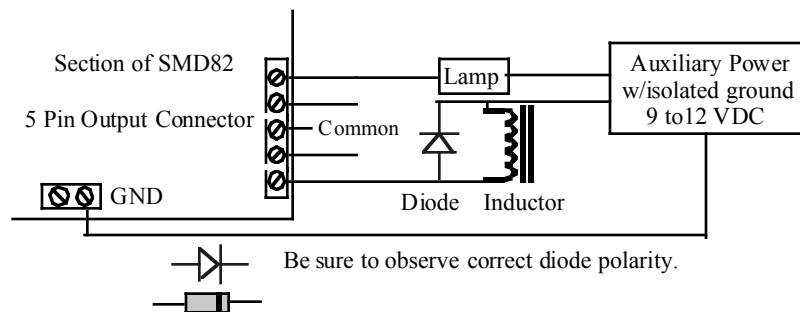

3 “Smart” Programming

“Smart” programming is a term used to describe a method to program Configuration Variables (CVs) using switch addresses. This method is a much easier way to program CVs. With “Smart” programming, you can set the output addresses and the output configuration for solenoid or stall type switch machines.

To program in “Smart” mode, connect the SMD82 RAIL A and RAIL B terminals to the track power. Turn on power.

To change the output addresses follow these steps.

1. Press the “Smart” program button and hold it down for approximately one second until LED1 (typically red) starts to flash. Then release it. The SMD82 is now ready to have the output addresses changed.
2. Using the throttle select the switch address you want for output 1 and issue a throw (reverse) command. LED2 (typically green) will flash briefly. LED1 now flashes twice with a pause and then repeats indicating that the output 2 address is ready to be programmed.
3. Again using the throttle select the switch address you want for output 2 and issue a throw (reverse) command. LED1 flashes three times with a pause and then repeats indicating that the output 3 address is ready to be programmed.
4. Repeat step three until you have programmed all the output addresses. The LED flashes increase indicating the output number. When all the output addresses have been programmed LED2 will turn on and LED1 will flash. At any time you can exit “Smart” mode by pressing the button for approximately one second until LED1 stops flashing.

To change the output configuration start from one of these places.

- 1a. Continue from step 4 above. LED2 is on and LED1 is flashing.
- 1b. Press the “Smart” program button and hold down for approximately three seconds until LED2 turns on. Then release it. LED1 will be flashing.
2. Using the throttle select any switch address you want. Issue a throw (reverse) command to configure output 1 for a stall type machine or a close (normal) command to configure it for a solenoid type machine. At this point, LED2 turns off. LED1 now flashes twice with a pause and then repeats indicating that output 2 is ready to be configured.
3. Again using the throttle, issue a throw (reverse) command to configure output 2 for a stall type machine or a close (normal) command to configure it for a solenoid type machine. LED1 now flashes three times with a pause and then repeats indicating that output 3 is ready to be configured.
4. Repeat the previous step until you have programmed all the output configurations. At any time you can exit “Smart” mode by pressing the button for approximately one second until LED1 stops flashing.

4 Configuration Variables (CVs)

The SMD82 supports **Paged Mode Programming in Service Mode and Ops Mode**. To program in paged mode, connect terminals Rail A and Rail B to the programming track. See diagram below. When power is applied, LED 1 will come on and LED 2 will flash when programming is successful. Some systems only apply power during actual programming, so LED1 will only be on during that time. The SMD82 does not have built in feedback like a mobile decoder. Because of this, some systems may show a “no decoder on track” error or “can not read CV”. However it still is programmed. NOTE: if you want to provide external feedback so any CV can be read, add a resistor as shown in the diagram below. Nothing else should be connected to output 1.

To enter normal operation, disconnect from the program track. Now connect terminals Rail A & B to the main track power.

Ops mode or “on the main” programming is very convenient because you can try out the CV changes almost immediately. In order to use this type of programming the ops mode loco address must be set in CV31 (default is 1) and option 3 must be set in CV29. **This is a loco address, so be careful when using this feature.** You can immediately start programming in “Power On” ops mode without programming CV29 by holding down the Smart button just before power is turned on. When LED2 turns on release the button. This temporarily sets option 3 until power is turn off. When using ops mode to change CV values, the SMD82 does not recognize the new values until power is turned off and then back on.

Program CV7 with 1 will restart the SMD82 so power need not be cycled when programming in ops mode. This is the same as turning power off and then back on.

Program CV7 with 170 will “reset” all CV’s to the factory default value. In page mode this may not work with some systems as they do not keep power applied to the programming track long enough for all the CVs to be programmed.

An easy way to “reset” to all factory defaults is to enter “Smart” programming and continue to hold the button down (at least 16 seconds) until both LEDs are alternately flashing. (Version 19 and above)

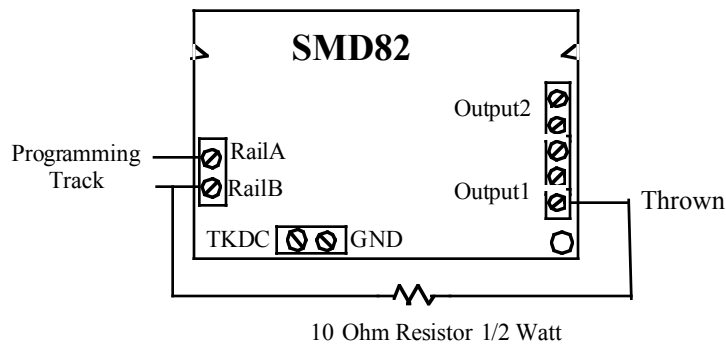

5 Connections

The primary input connector is a 10 pin flat ribbon cable (IDC) type. Jameco #138377 will work as the mating connector. 10 ft of gray flat ribbon cable is #643794. 10 ft of multicolor flat ribbon cable is #639672. If you want screw terminals for the primary inputs you can use our terminal strip adapter (TSA). The power, Aux inputs and outputs are screw terminals.

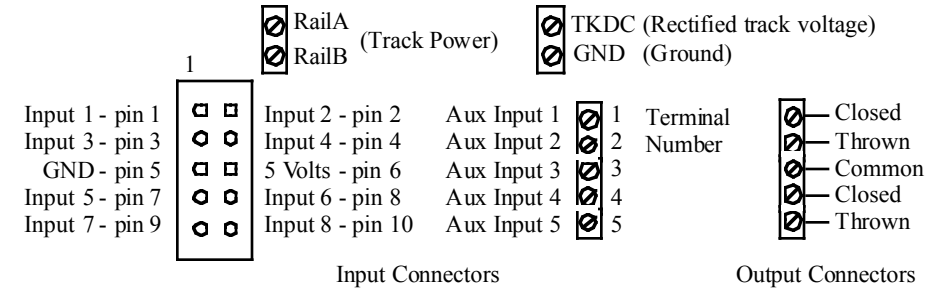

6 Applications

6.1 Routes

The SMD82 is well suited to handle routes in a yard. The following shows an example of five routes using four switches. The route CV values were determined using the information in sections 4.6 and 4.7. One very nice tool that makes custom programming much easier is JMRI DecoderPro.

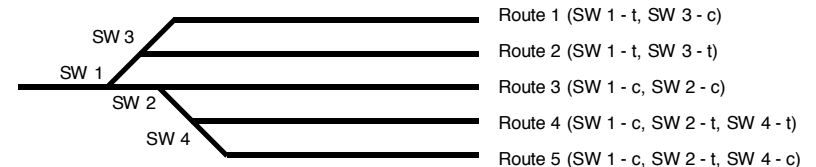

Route Group 1 - 8 address CV 77 = 101

SW 1 to 4 connected to SMD82 outputs 1 to 4 respectively

Route 1 CV 81 = 5, CV 82 = 1 execute with 101t

Route 2 CV 83 = 5, CV 84 = 5 execute with 101c

Route 3 CV 85 = 3, CV 86 = 0 execute with 102t

Route 4 CV 87 = 11, CV 88 = 10 execute with 102c

Route 5 CV 89 = 11, CV 90 = 2 execute with 103t

One SMD82 can handle routes with up to eight switches. However, it may be necessary to have routes with more than eight switches and consequently more than one SMD82. Multiple SMD82 can be programmed to operate together to execute a route with one command. Lets say you have a route with 16 switches. This would require two SMD82s.

The first SMD82 controls switches 1 to 8 and the second SMD82 controls switches 9 to 16. The CV 1 & 9 values should be different for each SMD82 giving them their own address because you still may want to control each switch individually. The SMD82 output addresses are independent of the route addresses.

4.8 Power On Output State

These CVs determine the state of each output at power on. Decoder configuration option 1 or option 2 has to be enabled for these CVs to function. You only need to program these CVs if option 2 is enabled. If option 1 is enabled, the SMD82 automatically programs them. CV33 - Power on state for outputs 1 to 4, a value from 1 to 170 CV34 - Power on state for outputs 5 to 8, a value from 1 to 170 If neither throw or closed is selected the output does nothing. If both are selected this feature will not work correctly

Outputs 1 to 4	Value	Select
Output 1 throw	1	1
Output 1 close	2	
Output 2 throw	4	4
Output 2 close	8	
Output 3 throw	16	
Output 3 close	32	32
Output 4 throw	64	64
Output 4 close	128	
Program this value into CV33		101

Outputs 5 to 8	Value	Select
Output 5 throw	1	
Output 5 close	2	2
Output 6 throw	4	
Output 6 close	8	8
Output 7 throw	16	16
Output 7 close	32	
Output 8 throw	64	64
Output 8 close	128	
Program this value into CV34		90

Example: CV33 = 1 + 4 + 32 + 64 = 101, throw output 1, throw output 2, close output 3 and throw output 4

Example: CV34 = 2 + 8 + 16 + 64 = 90, close output 5, close output 6, throw output 6 and throw output 6 (example shown above in table)

Tip: An easy way to program CV33 and CV34.

1. Enter normal operating mode and command each of the outputs to the desired state.
2. Enter programming mode and program CV29 to 2 (enable option 2).
3. Exit programming mode.

Now at each powered on, the outputs will go to the same state as set in step 1.

4.9 Output On Time

This CV determines how long an output will stay on. In order for this CV to function the output configuration CV must be set to a value of two (2). See section 4.2. This CV applies to all outputs set to this configuration. The default value of this CV is 31 which gives an on time of about 8 seconds.

CV2 - Output on time, a value of 1 to 127.

The time is determined by the following equation.

On time = CV2 X .256 seconds

4.10 Ops Mode Loco Address

This CV sets the operations mode program address. Program the SMD82 just like you would a loco in ops mode. This is a loco 2 digit address and therefore must be unique among locomotive addresses. Option 3 must be enabled to use this address for programming on the main. The programming track is not required once this address and option 3 have been set. TIP: If the "Smart" program button is pressed when is turned power on, option 3 is enable until power is removed. This is useful if you do not want to have ops mode enabled all the time.

CV31 - Ops mode address, a value of 1 to 127. Default is one (1).

4.1 Output Address

These CVs determine the address of the outputs. Each output address is constructed of two CVs, an address and an address adder. See section 7 for CV numbers. If an address greater than 255 is needed then the address adder value will be greater than zero. Otherwise the address is set by the address value only. The address adder value represents a number that is added to the address value to give the required address. The Address Adder table shows the CV value to use for the adder. For easier programming see "Smart" Programming.

Address, a value from 0 to 255, Address adder, a value from 0 to 7

Note: Some systems refer to CV1 as AD, AD2 or short address.

Examples for Output 1					
Required address	34	220	266	524	898
Address CV1 value	34	220	10	12	1280
Address Adder CV9 value	0	0	1	2	3

Address Adder								
CV value	0	1	2	3	4	5	6	7
Add	0	256	512	768	1024	1280	1536	1792

4.2 Output Configuration

These CVs determine the output type.

CV3, 4, 5, 6, 10, 11, 12, 13- Output configuration

Set the CV value to zero ("0") for solenoid type operation.

Set the CV value to one ("1") for stall motor (continually on) type operation.

Set the CV value to two ("2") for 8 second motor on type operation (not queued). If the motor doesn't have to be continually powered, use this type to reduce track current draw. The length can be adjusted by changing the value of CV2.

Set the CV value to four ("4") for on/off manual motor control type operation. This type doesn't response if included in a route.

4.3 Decoder Configuration

This CV determines the decoder configuration options.

CV29 - Configuration, a value from 0 to 4

Option 1, CV29 = 1 The SMD82 will remember each outputs state at power off. Then at power on, after about five seconds, each output will be set to the same state. The output state is automatically stored in CV33 and CV34.

Option 2, CV29 = 2 At power on, after about five seconds, each output will be set to the state as determined by CV33 and CV34. You must program CV33 and CV34 to the desired state at power on. Option 2 disables option 1. See section 4.8.

Option 3, CV29 = 4 Enables ops mode programming. This allows the address in CV31 to be used as if it is a "loco" address and can be programming on the main. See section 4.10. To combine options add their value together. In the case where only one selection is possible a box shows "Select one".

Example: Enable options 2 and 3, CV29 = 2 + 4 = 6

Configuration CV	Value	Select
No options	0	
Option 1 - enable output memory	1	Select One
Option 2 - enable fixed output at power on	2	
Option 3 - enable ops mode (on the main) programming	4	
Program this value into the configuration CV		

4.4 Input Control

These CVs determine what action the inputs will have when activated. There are two CVs for each input. A route number of one of the routes and an action. See section 7 for CV numbers.

There are 13 physical input terminals. Eight primary and five auxiliary. If you require more than 13, you can use the secondary inputs which use the same terminal as the primary inputs but require the use of a resistor as shown in the diagram.

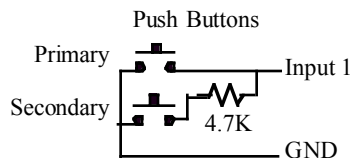

Primary input 1 and aux input 1, primary input 2 and aux input 2 ...etc work together and optionally can be configured so that the aux input would only execute its assigned route when the primary input is low.

The following table shows how each CV is defined and the value of each selection. Add the value of the selections together to determine the value to program the CV. To select a given output multiply its number (1-8) by 16. In some cases only one of several selections are possible and are shown by a box as "Select one".

Pri, Sec & Aux Input Control			
Route Number CV	Value	Select	
Route Disabled	0	0	Select
Route Number (result of transition if selected)	1 to 16		One
Route will only execute if respective Pri input low *	128		
Program this value into the appropriate route number CV		0	
Action CV			
Input disabled	0		Select
On low to high transition**	1		one
On high to low transition	2	2	
On change transition (both low to high and high to low)**	3		
<i>Result of transition if route number CV value is (0) zero</i>			
Transition toggles output	4	4	Select
Transition closes the output	0		One
Transition throws the output	8		
Output number times 16	# X 16 1 X 16	16	
Program this value into the appropriate action CV		22	

* Only applies to routes assigned to Aux inputs

** Not recommended for secondary inputs

In order for an input to cause an action, a transition must be selected. Each input has a 'pull-up' resistor connected to 5 volts, so the input is normally at 5 volts. An input transition is when the voltage on an input goes from high to low (falling edge) or from low to high (rising edge). For example, if a push button is connected to an input and ground, when it is pressed the input is grounded. This causes a high to low transition. When the button is released this causes a low to high transition.

Example: Primary input 1 when grounded will toggle output 1.

Route number CV35=0, Action CV36=2+4+16=22 (example shown above in table)

Example: Primary input 2 when grounded will execute route 2.

Route number CV37=2, Action CV38=2+32=34 (When a route is enabled, the close, throw, toggle and output number are disabled. Set the values to zero (0) for ease in programming.)

Tip: Use ops mode to quickly experiment with input settings.

4.5 Remote Control Route Address

There are 16 possible routes that are divided into two groups, 1 to 8 and 9 to 16. Each route group has an execution address which is constructed of two CVs, an address and an address adder. The address of the route group is independent of the SMD82 output addresses. See section 7 for CV numbers. If an address greater than 255 is needed then the address adder value will be greater than zero. Otherwise the address is set by the address value only. See section 4.1 for more information. A route execution address is further defined throw or close is used to issue the address.

Note: The group 1-8 address should be at least four numbers apart from the group 9-16 address or the routes will not work correctly.

Example: CV77 = 101, CV78 = 0, throw switch 101 to execute route 1, close switch 101 to execute route 2.

Route Group 1-8 Execution Example								
Route	1	2	3	4	5	6	7	8
Switch address	101t	101c	102t	102c	103t	103c	104t	104c

4.6 Route Output Selection

These CVs determine which output is included in the route. Each of the eight outputs has its own value. To calculate the CV value, add up all the individual values of the outputs to be included (selected). An excluded output has a value of zero. See section 7 for CV numbers. Example: For route 1, select outputs 1, 2, 4 and 6. CV81 = 1+2+8+32 = 43.

Route Selection CV	Value	Select	Example
Output 1	1		1
Output 2	2		2
Output 3	4		0
Output 4	8		8
Output 5	16		0
Output 6	32		32
Output 7	64		0
Output 8	128		0
Program this value into the appropriate selection CV			43

4.7 Route Switch State

These CVs determine the state, closed or thrown, of the switch. Each of the eight outputs has a close and throw value. A close always has a zero (0) value. A throw has a value greater than zero. To calculate the CV value, add up all the throw values (close is zero). If an output is not selected set the value to zero (0).

Example: From section 4.6, four outputs have been selected. For remote route 1, close outputs 2 and 4, and throw outputs 1 and 6. CV82 = 1+32 = 33.

Switch State CV	Value	Select	Example
Output 1 throw - not selected (0) closes	1		1
Output 2 throw - not selected (0) closes	2		0
Output 3 throw - not selected (0) closes	4		0
Output 4 throw - not selected (0) closes	8		0
Output 5 throw - not selected (0) closes	16		0
Output 6 throw - not selected (0) closes	32		32
Output 7 throw - not selected (0) closes	64		0
Output 8 throw - not selected (0) closes	128		0
Program this value into the appropriate state CV			33